

X-55

INSTALLATION AND OPERATION INSTRUCTIONS

LITHO IN U.S.A.

988-0136-07

LOWRANCE ELECTRONICS, INC.
12000 E. SKELLY DR., TULSA, OK 74128

TABLE OF CONTENTS

INTRODUCTION	1
MOUNTING	1
POWER CONNECTIONS	2
TRANSDUCER	3
KEYBOARD BASICS	3
DISPLAY	4
MENUS	5
HELP	5
WINDOWS	5
VIEWING WINDOWS OPTIONS	7
MODIFYING GROUPS	7
RESETTING ALL GROUPS	8
SIDE SCAN OPERATION	8
SONAR OPERATION	9
AUTOMATIC	9
SENSITIVITY	10
RANGE	11
Upper and Lower Limits	11
ZOOM - Automatic Operation	12
ZOOM - Manual Operation	13
ALARMS	14
FISH ALARM	14
ZONE ALARM	15
DEPTH ALARMS	16
ALARM MUTE	17
MENU - PAGE 1	18
CHART SPEED	18
GRAYLINE®	18
FISH I.D.	19
DISPLAY CONTRAST	20
MENU - PAGE 2	21
ADJUST BACK LIGHT LEVEL	21
BACK LIGHT ON/OFF	21
SPEAKER VOLUME	21
TURN DIGITAL BOX OFF	22
CONSTRUCT DIGITAL BOX	22
MENU - PAGE 3	23
CHART CURSOR	23
DISPLAY ZOOM BAR	23
DISPLAY ZONE BAR	24
DIGITAL SONAR	24
MENU - PAGE 4	24
FASTRAK	24
SELECT UNITS OF MEASURE	25
CLEAR DISTANCE LOG	25
MENU - PAGE 5	26
ADJUST CHART SURFACE CLARITY	26
ADVANCED SIGNAL PROCESSING (ASP)	26
SIGNAL INTERPRETATION	27
TRANSDUCERS AND CONE ANGLES	28
FISH ARCHES	28
WATER TEMPERATURE AND THERMOCLINES	30
SURVEYING A LAKE	31
BAIT FISH	32
SONAR TROUBLESHOOTING	33

Copyright® 1992 Lowrance Electronics
All rights reserved.

All features and specifications subject to change without notice.
All screens in this manual are simulated.

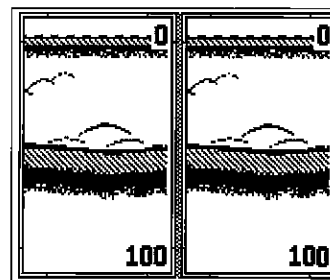

GROUP "H"

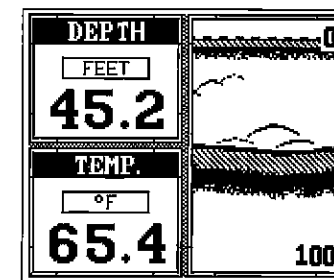

GROUP "I"

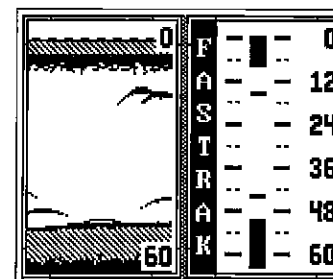

GROUP "J"

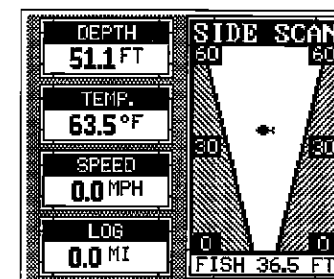

GROUP "K"

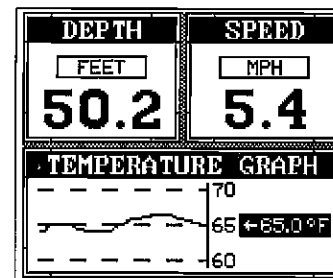

GROUP "L"

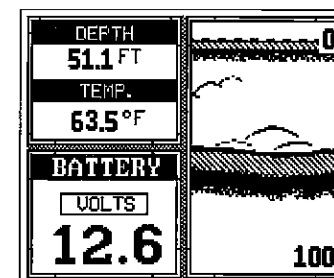

GROUP "M"

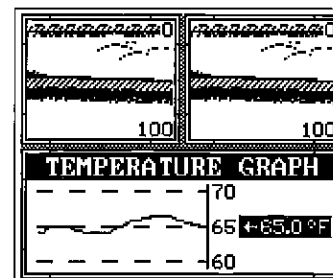

GROUP "N"

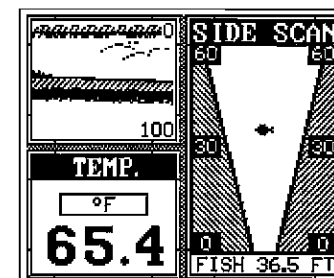

GROUP "O"

WINDOWS SUMMARY

All of the window groups used by the X-55 are shown on the following pages. To view these groups, simply press the WINDOWS key, then repeatedly press the down arrow key. This will "cycle" the unit through all groups. Remember, each group can be customized, however the group will revert to the ones shown on these pages when the unit is turned off.

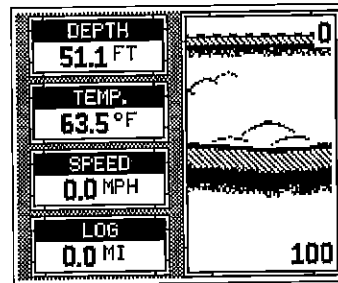

GROUP "A"

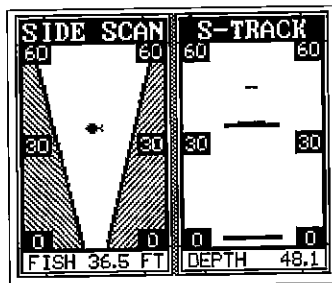

GROUP "B"

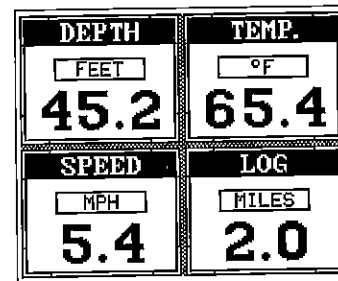

GROUP "C"

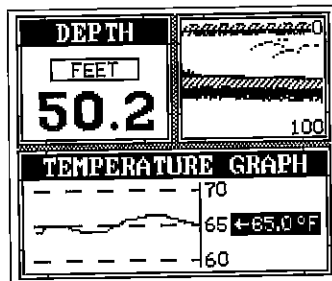

GROUP "D"

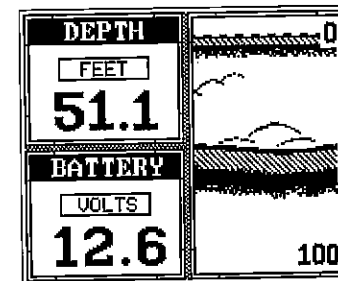

GROUP "E"

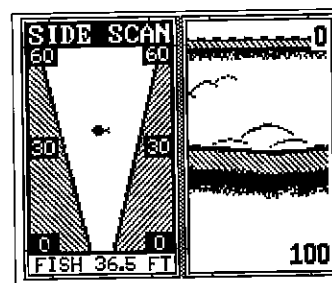

GROUP "F"

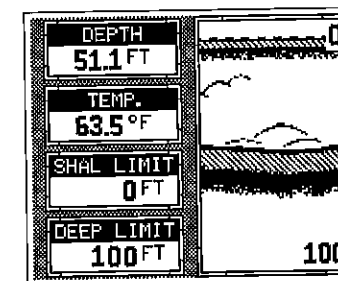

GROUP "G"

INTRODUCTION

The X-55 is a high quality, wide screen sonar with performance that is second to none in its class. Using menu features and "soft-key" operation, the X-55 is also one of the easiest-to-use sonars that Lowrance has ever built. The wide "Clearvision" screen shows the underwater world with high resolution and detail. The display and keyboard are also lighted for night operation. The X-55 also has digital depth, boat speed, surface water temperature, and distance travelled (log) displays. In order to use the digital speed, temperature, and log displays, you must purchase and install an optional ST-T (transom mount) or ST-H (through-hull mount) speed/temperature sensor.

Read this manual and take it with you the first few times you use your unit. It makes a great reference if you need it.

MOUNTING

Install the X-55 in any convenient location, provided there is clearance behind the unit when it is tilted for the best viewing angle. Holes in the bracket base allow wood screw or through-bolt mounting. You may need to place a piece of plywood on the back of thin fiberglass panels to secure the mounting hardware. Make certain there is enough room behind the unit to attach the power and transducer cables.

The smallest hole that will pass one power or transducer plug is one inch. After the hole is drilled, pass the transducer connector up through the hole first, then pass the power cable down through it.

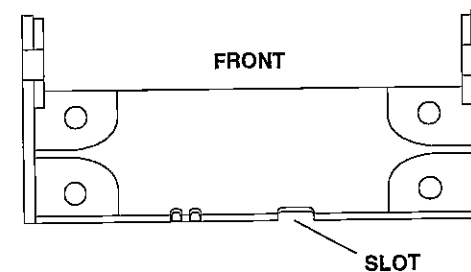

After the cables have been routed, fill the hole with a good marine sealing compound. Offset the bracket to cover the hole. Route the power cable through the slot and break out one of the other slots in the bracket for the transducer cable.

POWER CONNECTIONS

The X-55 works from a twelve-volt battery system. For the best results, attach the power cable directly to the battery. You can attach the power cable to an accessory or power buss, however you may have problems with electrical interference. Therefore, it's safer to go ahead and attach the power cable directly to the battery. If the cable is not long enough, splice #18 gauge wire onto it. The power cable has two wires, red and black. Red is the positive lead, black is negative or ground. Make certain to attach the in-line fuse holder to the red lead as close to the power source as possible. For example, if you have to extend the power cable to the battery or power buss, attach one end of the fuse holder directly to the battery or power buss. This will protect both the unit and the power cable in the event of a short. The X-55 uses a 3-amp fuse.

IMPORTANT!

Do not use this product without a 3-amp fuse wired into the power cable! Failure to use a 3-amp fuse will void your warranty.

If you're installing an optional speed/temperature sensor, read the speed/temperature sensor's installation manual for mounting instructions. Route the sensor's cable to the X-55's power cable and plug it into the connector marked "SPEED/TEMP CABLE"

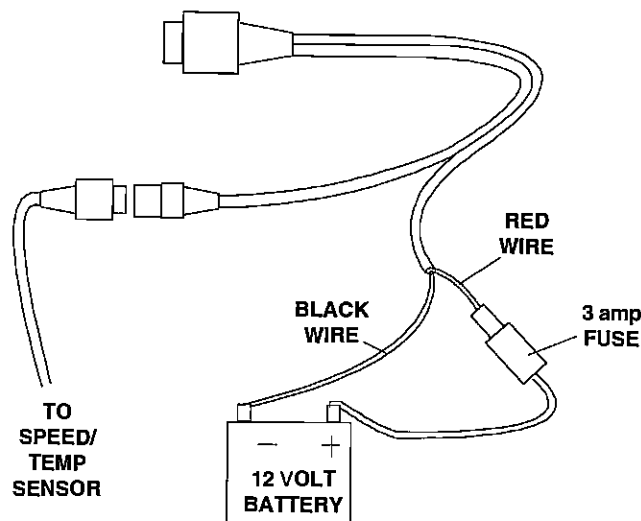

X-55 POWER CONNECTIONS

NOISE

A major cause of sonar problems is electrical noise. This usually appears on the sonar's display as random patterns of dots or lines. In severe cases, it can completely cover the screen with black dots, or cause the unit to operate erratically, or not at all.

To eliminate or minimize the effects of electrical noise, first try to determine the cause. With the boat at rest in the water, the first thing you should do is turn all electrical equipment on the boat off. Make certain the engine is off, also. Turn your X-55 on, then turn off ASP (Advanced Signal Processing). There should be a steady bottom signal on the display. Now turn on each piece of electrical equipment on the boat and view the effect on the sonar's display. For example, turn on the bilge pump and view the sonar display for noise. If no noise is present, turn the pump off, then turn on the VHF radio and transmit. Keep doing this until all electrical equipment has been turned on, their effect on the sonar display noted, then turned off.

If you find noise interference from an electrical instrument, trolling motor, pump, or radio, try to isolate the problem. You can usually re-route the sonar unit's power cable and transducer cable away from the wiring that is causing the interference. VHF radio antenna cables radiate noise when transmitting, so be certain to keep the sonar's wires away from it. You may need to route the sonar unit's power cable directly to the battery to isolate it from other wiring on the boat.

If no noise displays on the sonar unit from electrical equipment, then make certain everything except the sonar unit is turned off, then start the engine. Increase the RPM with the gearshift in neutral. If noise appears on the display, the problem could be one of three things; spark plugs, alternator, or tachometer wiring. Try using resistor spark plugs, alternator filters, or routing the sonar unit's power cable away from engine wiring. Again, routing the power cable directly to the battery helps eliminate noise problems. Make certain to use the in-line fuse supplied with the unit when wiring the power cable to the battery.

When no noise appears on the sonar unit after all of the above tests, then the noise source is probably cavitation. Many novices or persons with limited experience make hasty sonar installations which function perfectly in shallow water, or when the boat is at rest. In nearly all cases, the cause of the malfunction will be the location and/or angle of the transducer. The face of the transducer must be placed in a location that has a smooth flow of water at all boat speeds. Read your transducer owner's manual for the best mounting position.

3. The water may be deeper than the sonar's ability to find the bottom. If the sonar can't find the bottom signal while it's in the automatic mode, the digital will flash continuously. It may change the range to limits far greater than the water you are in. If this happens, place the unit in the manual mode, then change the range to a realistic one, (for example, 0-100 feet) and increase the sensitivity. As you move into shallower water, a bottom signal should appear.

4. Check the battery voltage. If the voltage drops, the unit's transmitter power also drops, reducing its ability to find the bottom or targets.

Bottom echo disappears at high speeds or erratic digital reading or weak bottom echo while boat is moving

1. The transducer may be in turbulent water. It must be mounted in a smooth flow of water in order for the sonar to work at all boat speeds. Air bubbles in the water disrupt the sonar signals, interfering with its ability to find the bottom or other targets. The technical term for this is Cavitation.

2. Electrical noise from the boat's motor can interfere with the sonar. This causes the sonar to automatically increase its Discrimination or noise rejection feature. This can cause the unit to eliminate weaker signals such as fish or even structure from the display. Try using resistor spark plugs or routing the sonar unit's power and transducer cables away from other electrical wiring on the boat.

No fish arches when the Fish ID feature is off:

1. Make certain transducer is pointing straight down. This is the most common problem if a partial arch is displayed. See the Fish Arch section in your owner's manual for more information.

2. The sensitivity may not be high enough. In order for the unit to display a fish arch, it has to be able to receive the fish's echo from the time it enters the cone until it leaves. If the sensitivity is not high enough, the unit displays the fish only when it is in the center of the cone.

3. Use the Zoom feature. It is much easier to display fish arches when zoomed in on a small range of water than a large one. For example, you will have much better luck seeing fish arches with a 30 to 60 foot range than a 0 to 60 foot range. This enlarges the targets, allowing the display to show much more detail.

4. The boat must be moving at a slow trolling speed to see fish arches. If the boat is motionless, fish stay in the cone, showing on the display as straight horizontal lines.

TRANSDUCER CONNECTIONS

See the transducer owner's manual included with the unit for complete transducer installation instructions.

SIDE SCAN

The X-55 has optional side-scan capability. To use this feature, you must purchase the ScanPac accessory. To install it, follow the instructions enclosed with the ScanPac.

See the "Side Scan Operation" section in this manual for information on using the side-scan feature.

SPEED/TEMPERATURE/DISTANCE LOG

To use the speed, temperature, and distance log features, you must install an optional speed/temperature sensor. Lowrance manufactures a thru-hull sensor/transducer combination unit and a transom mount speed/temp only sensor.

KEYBOARD

The keyboard has keys arranged in two vertical columns plus a horizontal row at the bottom. The keys in the left column are used to enter numbers and menu selections. The keys in the right column activate the windows feature and the basic sonar functions. The menu key in the bottom right corner of the keyboard activates the first menu page. The keys along the bottom of the screen are used to activate the alarm menu, stop the chart, and make menu selections with the arrow keys.

WINDOWS - This key gives you access to the windows mode, which lets you customize displays.

SENS - Press this key to adjust the unit's sensitivity.

RANGE - This key lets you adjust the range when the unit is in the manual mode.

ZOOM - The X-55 gives you 2X and 4X zoom capability with this key.

AUTO - This turns the automatic feature off and on.

MENU - Press this key to show the menus and gain access to most functions.

CLEAR - This key clears menus and erases entries from the screen.

ALARM - Press this key to activate any of the sonar alarms.

STOP - When this key is pressed, the chart stops scrolling. This doesn't affect the digital display, however.

ARROW KEYS - These keys are used to make menu selections and to move objects on the screen.

ON - The ON key turns the X-55 on.

OFF - Press and HOLD the Off key to turn the X-55 off.

DISPLAY - General

The lights are turned on for approximately ten seconds when the X-55 is first turned on. Menus appear at the same time. To keep the lights on, press the key adjacent to the Light label. It controls the backlighting used on the display and keyboard. If you don't want the lights on, wait ten seconds and the lights will automatically turn themselves off. The menus will also disappear after ten seconds, or you can turn them off by pressing the CLEAR key at the bottom of the screen.

The Metric label at the top of the screen works the same way. Press the key adjacent to the Metric label to change the depth from feet to meters. This also changes the temperature display to degrees Celsius, speed to knots, and log to kilometers on the X-55.

The Display menu at the bottom of the screen lets you adjust the display's contrast for the best viewing angle. Pressing the left arrow key decreases the contrast, the right arrow increases it. After setting the contrast for the best viewing angle, press the CLEAR key to erase the menu or wait approximately ten seconds and it will automatically erase. See the Display Contrast section for more information on this feature.

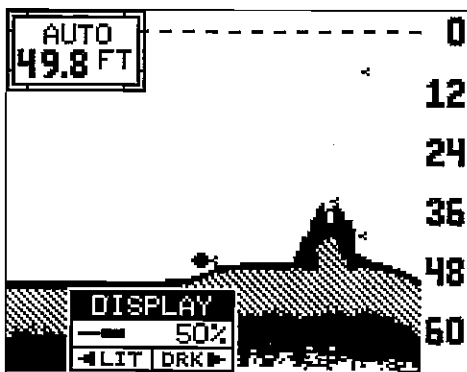

When the X-55 is first turned on, the display will appear similar to the one at left. The word "AUTO" in the upper left corner of the display indicates the automatic feature is on. The digital bottom depth is also displayed in this box.

IMPORTANT SERVICE INFORMATION!

If your unit is not working, or if you need technical help, please use the following troubleshooting section before contacting the factory customer service department. It may save you the trouble of returning your unit.

Unit won't turn on:

1. Check the power cable's connection at the unit. Also check the wiring.
2. Make certain the power cable is wired properly. The red wire connects to the positive battery terminal, black to negative or ground.
3. Check the fuse.
4. Measure the battery voltage at the unit's power connector. It should be at least 11 volts. If it isn't, the wiring to the unit is defective, the battery terminals or wiring on the terminals are corroded, or the battery needs charging.

Unit freezes, locks up, or operates erratically:

1. Electrical noise from the boat's motor, trolling motor, or an accessory may be interfering with the sonar unit. Re-routing the power and transducer cables away from other electrical wiring on the boat may help. Route the sonar unit's power cable directly to the battery instead of through a fuse block or ignition switch.
2. Inspect the transducer cable for breaks, cuts, or pinched wires.
3. Check both the transducer and power connectors. Make certain both are securely plugged in to the unit.

Weak bottom echo, digital readings erratic, or no fish signals:

1. Make certain transducer is pointing straight down. Clean the face of the transducer. Oil, dirt, and fuel can cause a film to form on the transducer, reducing its effectiveness. If the transducer is mounted inside the hull, be sure it is shooting through only one layer of fiberglass and that it is securely bonded to the hull. Do NOT use RTV silicone rubber adhesive or Marinetex.
2. Electrical noise from the boat's motor can interfere with the sonar. This causes the sonar to automatically increase its Discrimination or noise rejection feature. This can cause the unit to eliminate weaker signals such as fish or even structure from the display.

With the X-55, anyone can eliminate guesswork and concentrate on the areas where fish are likely to be. Even if it's the first time on the lake!

The most efficient way to become acquainted with a body of water is to survey it with your X-55. Start with a map of the lake, if possible, and indicate the promising spots in relation to landmarks on shore.

As you go about your survey, your X-55 will tell you the depth and type of bottom. It will also reveal suspended fish.

Keep a few marker buoys in the boat, ready to toss overboard. When the X-55 indicates a school of fish, throw the buoy out. With the school thus marked, you can make your turn and come back to fish in exactly the right spot. This is essential when you're far from shore on a big lake. Unless you mark the school of fish when you're over it, you may not be able to find it again.

BAIT FISH

The importance of bait fish to successful fishing can't be over-emphasized. They are the principle food of all game fish in most waters.

Bait fish are the plankton feeding forage fish, such as minnows and shad. Bait fish can also be the young of game fish, such as crappies, bluegill, and bass.

Most bait fish concentrate within five feet of the surface where sunlight promotes the growth of the plankton on which they feed. One method of fishing is to use the X-55 to find the bait fish first. With the Fish ID feature off, a school of bait fish will look like a "cloud" on the display. Usually, game fish will be nearby, often directly beneath the school of bait fish.

MENUS

The X-55 uses menus extensively to guide you through the functions and features of the unit. The menu key accesses many of these features, allowing you to customize the unit to your particular needs and water conditions. Although you may have to leave one menu and enter another to reach the desired function, all you have to do is press the menu key to select the next menu. If you ever get lost in a menu, simply press the CLEAR key.

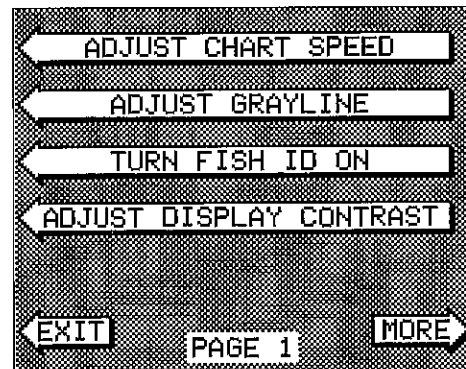

HELP

An extremely useful feature incorporated into the X-55 series is the Help menus. Virtually every feature has a help menu label that, when pressed, gives one or more pages of text describing how to use that feature. For example, pressing the AUTO key brings up a menu letting you switch the unit into or out of the automatic mode. A help label also appears on the screen. Pressing the key adjacent to the help label gives you a description of how automatic works and how it affects different functions.

WINDOWS

You can change the displays on the X-55 by using the windows feature. This lets you customize displays to your own fishing or boating situations. This feature also gives you 15 window display screens on the X-55.

The screens available in the windows mode are divided into two or more windows per screen. Each screen of windows is called a "group". Group "A" as shown at right has the digital displays in one window and the sonar chart in the other.

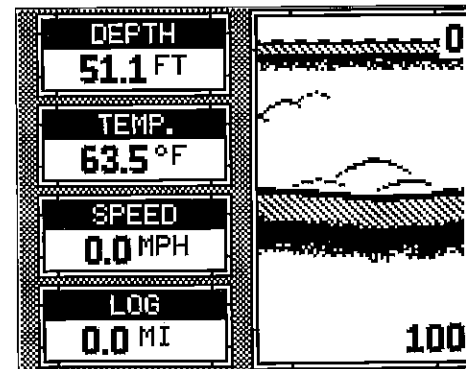

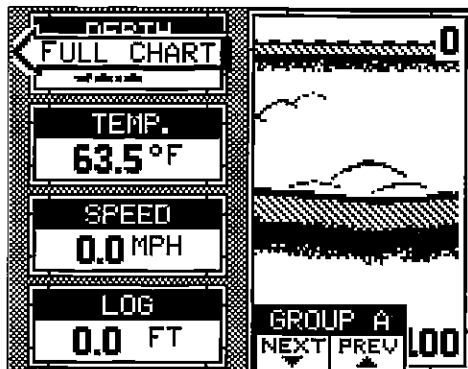

To use the windows feature, first press the WINDOWS key. A screen similar to the one shown at left appears. The menu at the bottom of the screen lets you switch between the "pages" of displays. These are lettered "A" through "O". Group "A" shows first. Press the down arrow key to move forward through the screens. Press the up arrow key to

move backward. For example, pressing the down arrow key once shows the group "B" screen which is the side scan screen. To return to the full sonar screen, press the key next to the "FULL CHART" label at the top of the screen.

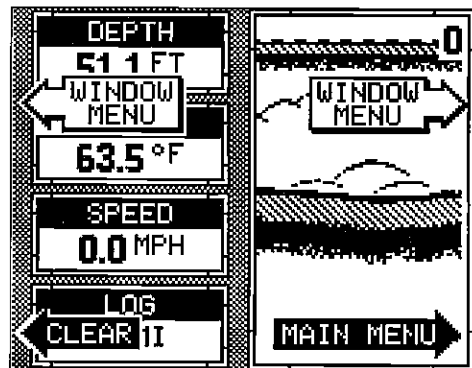

Every one of the group screens can be modified to some extent. For example, press the MENU key while group "A" is displayed. Four new labels appear on the display as shown above. Two of these labels are window menus. Pressing the key adjacent to one of the "window menu" labels gives you a menu with functions that relate only to that window. For example, if you press the key adjacent to the window menu label on the sonar chart window, the screen will clear and you will have a new menu with selections such as "ADJUST CHART SPEED" and "ADJUST GRAYLINE". Other window menus let you change the units of measure or adjust alarms.

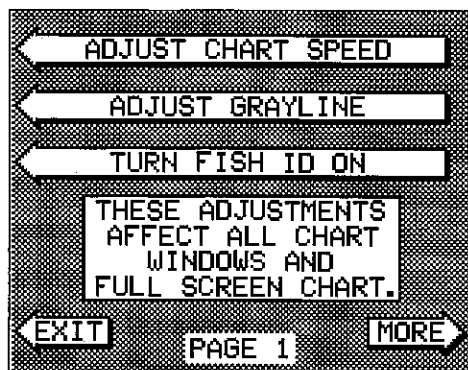

To exit from a window menu, press the CLEAR key.

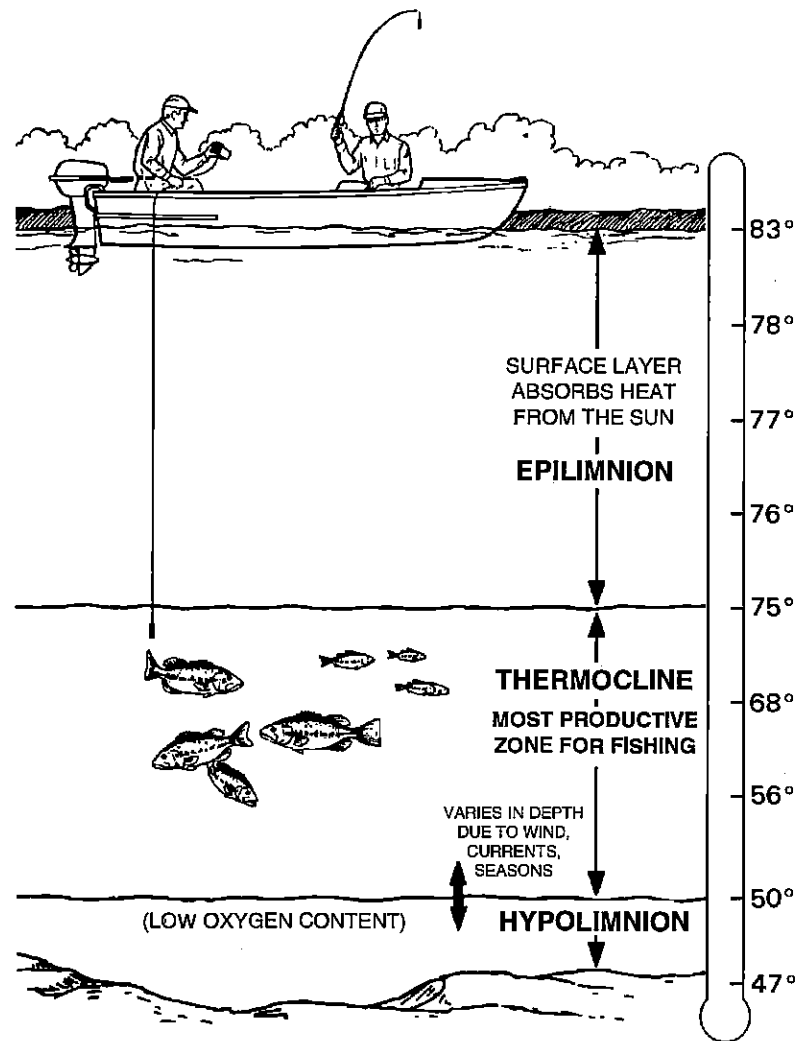

SURVEYING A LAKE

The most successful anglers on any body of water are those who fish it day after day and year after year. Eventually, they learn the hot spots that produce fish consistently. They discover through experience where, and at what depth, they can expect to find the fish they want at any season. And they realize that these productive areas change throughout the year depending on water level, temperature, food, and other factors.

of the water. For example, from 45 to 60 feet. The smaller the segment, the better the screen resolution will be. The easiest way to do this on the X-55 is with the Zoom feature. This feature expands the echoes, making it easier to see detail. For the best results, turn the sensitivity up as high as possible without getting too much noise on the screen. In medium to deep water, this method should work to display fish arches.

If you see fish signals when the unit is in the manual mode, but don't get fish symbols when the Fish I.D. feature is on, try increasing the sensitivity.

WATER TEMPERATURE AND THERMOCLINES

Water temperature has an important-if not controlling-influence upon the activities of all fish. Fish are cold blooded and their bodies are always the temperature of the surrounding water. During the winter, colder water slows down their metabolism. At this time, they need about a fourth as much food as they consume in the summer.

Most fish don't spawn unless the water temperature is within rather narrow limits. A surface temperature meter helps identify the desired surface water spawning temperatures for various species. Trout can't survive in streams that get too warm. Bass and other fish eventually die out when stocked in lakes that remain too cold during the summer. While some fish have a wider temperature tolerance than others, each has a certain range within which it tries to stay. Schooling fish suspended over deep water lie at the level that provides this temperature. We assume they are the most comfortable here.

The temperature of water in the lake is seldom constant from top to bottom. Layers of different temperatures form, and the junction of a warm and cool layer of water is called a thermocline. The depth and thickness of the thermocline can vary with the season or time of day. In deep lakes there may be two or more at different depths. Thermoclines are important to fishermen because they are areas where fish are active. Many times bait fish will be above the thermocline while larger game fish will suspend in or just below it.

The X-55 can detect this invisible layer in the water, but the sensitivity will probably have to be turned up to see it.

VIEWING WINDOWS OPTIONS

To see all of the available window options, press the WINDOWS key, then press the MENU key. Now press the key adjacent to the "MAIN MENU" label. Finally, press the key next to the "VIEW ALL WINDOWS" label. The screen at right appears.

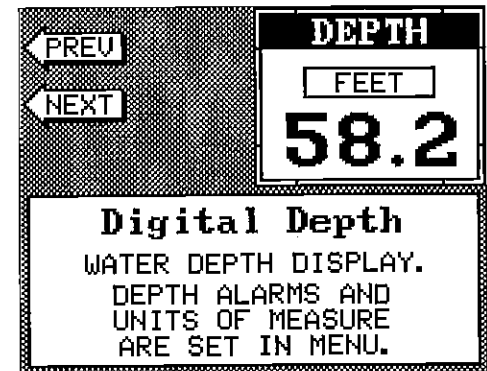

The first window appears in the upper right corner of the screen. A description of the screen shows in the box at the bottom of the screen. Now press the key adjacent to the "NEXT" label. This changes the displayed window and description.

When you've finished viewing the windows, press the CLEAR key.

MODIFYING GROUPS

To modify or "customize" a group, first press the WINDOWS key, then press the MENU key. Now press the key adjacent to the "MAIN MENU" label at the bottom of the screen. The screen shown below appears.

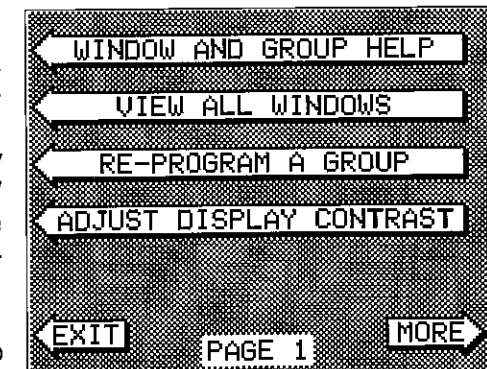

Now press the key adjacent to the "RE-PROGRAM A GROUP" label. The screen shown below appears.

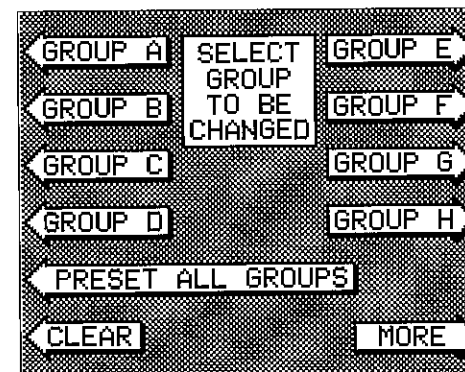

Select the letter of the group you wish to customize by pressing the key adjacent to the group's label. If the label isn't shown on this page, press the key adjacent to the "MORE" label. In this example, the key next to the "GROUP A" label was pressed. The screen shown at the top of the next page appears.

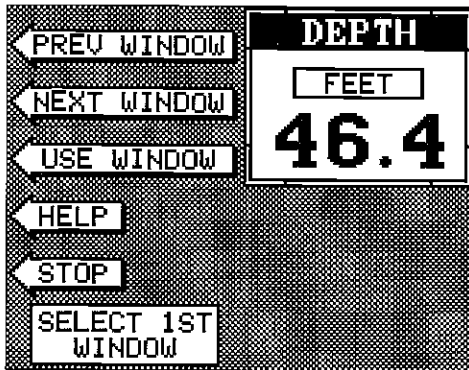

The depth window appears in the upper right corner of the screen. Press the key adjacent to the "NEXT WINDOW" label to move through the windows. If you reach the last window, or if you wish to go backwards through the windows, press the key next to the "PREV WINDOW" label. When the desired window is on the screen, press the key next to the "USE WINDOW" label. The screen clears,

placing the new window in the upper left corner of the screen. If the new window takes up half the screen, the unit will place it on the left side of the screen.

Continue with the window selections until the screen is filled. The unit will stay in the windows mode using your new customized screen. If you don't want to fill a screen and only use one, two, or three windows in a group, simply press the key adjacent to the "STOP" label. This saves the group and exits the modify windows mode.

Remember, you can always return to the full screen sonar mode by pressing the "0" key in the upper left corner. To switch back to your customized screen from the full screen sonar, simply press the WINDOWS key, then use the down arrow key to switch to the group you customized.

NOTE: Turning the unit off erases all customized screens and user settings!

RESETTING ALL GROUPS

To return all of the groups to their factory settings without turning the unit off and on again, press the WINDOWS key, then press the MENU key, then press the key adjacent to the "MAIN MENU" label. Now press the key adjacent to the "RE-PROGRAM A GROUP" label. Finally, press the key next to the "RESET ALL GROUPS" label.

SIDE-SCAN OPERATION

Two different side scan displays are available when the X-55 is in the Windows mode. To use the side scan feature, first install the ScanPac transducer on your trolling motor. Next, press the WINDOWS key on the X-55 unit.

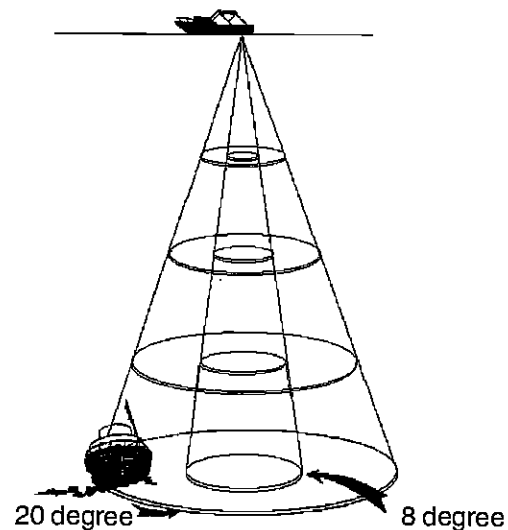

TRANSDUCER CONE ANGLES

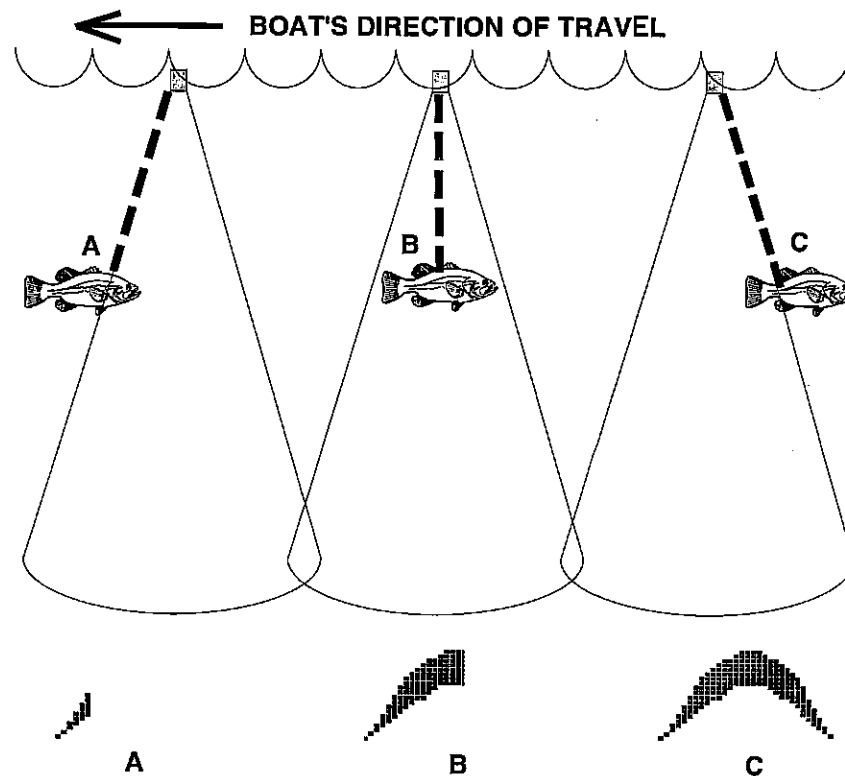

TRANSDUCER CONE ANGLES

The sound waves from the transducer spread out into the water in a cone shaped beam. This looks much like the beam from a flashlight. The angle between the outside edges of the cone is the cone angle.

Lowrance offers a choice of transducers with either an 8 or 20 degree cone angle. The transducer supplied with the X-55 has a 20 degree cone angle. Typically, wide cone angle transducers (20 degrees) are ideal for operating in shallow to medium water depths. The 20 degree cone angle allows you to see more of the underwater world. In 15 feet of water the 20 degree cone covers an area about six feet across. The 8 degree transducer covers only about a two foot circle.

The 20 degree transducer is almost always the best to use in fresh water, the 8 degree mostly in salt water. In a deep water environment, (300 feet - fresh water, 100 feet - salt water) the narrow cone angle is more desirable. Since the sound energy is concentrated in a smaller area, it can penetrate to much deeper depths.

Both 8 degree and 20 degree transducers give accurate bottom readings, even though the bottom signal is much wider on the 20 degree model. This is because you are seeing more of the bottom. Remember, the shallow edge of the signal shows you the true depth. The rest of the signal tells you whether you are over rocks, mud, etc.

if the cone passes over a fish in shallow water, the signal displayed on the X-55 may not arch at all. This is due to the narrow cone diameter and the resolution limitations of the display.

FISH ARCHES

Fish arches are created when the cone of sound passes over a fish. The distance to a fish when the cone first strikes it is shown as "A" on the next page. When the center of the cone strikes the fish, the distance is shorter as shown "B". As the cone leaves the fish, the distance increases again as shown in "C".

Very small fish probably will not arch at all. Medium sized fish will show a partial arch, or a shape similar to an arch if they're in deep water. Large fish will arch, but turn the sensitivity up in deeper water to see the arch. Because of water conditions, such as heavy surface clutter, thermoclines, etc., the sensitivity sometimes cannot be increased enough to get fish arches.

One of the best ways to get fish arches is to expand or "zoom" a segment

Now press the down arrow key until the screen shown at right appears.

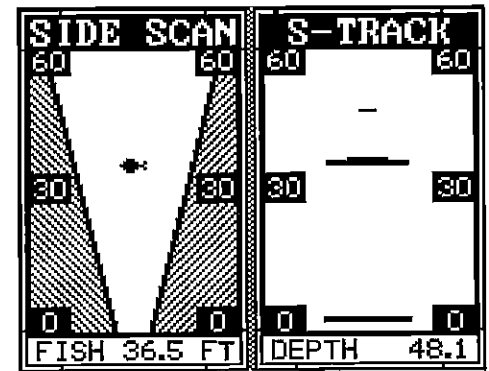

These are the side scan windows. Both windows show the digital depth display from the transducer pointed at the bottom - Not the side scan transducer. The window on the left shows a Fish ID symbol when the unit identifies a target as a fish. When this happens, the digital depth display at the bottom of the window changes from "DEPTH" to "FISH" and shows the distance from the side scan transducer to the target shown as a fish symbol.

The window on the right shows all return echoes. These echoes appear as short, horizontal lines. The thicker the line, the stronger the return echo. The distance to these targets can be determined by comparing the position of the echo to the range markers on the side of the display.

To change the range, press the RANGE key. A new menu appears at the bottom of the display. Use the up or down arrow keys to change the range of the side scan mode from ten to sixty feet. Either wait a few seconds after you've changed the range and the menus will automatically disappear or press the CLEAR key to erase the menus.

SONAR OPERATION - AUTOMATIC

When the X-55 is first turned on, the Automatic feature is enabled. This is indicated by the word "AUTO" at the top of the screen. The Automatic feature adjusts the sensitivity and range so the bottom signal is displayed in the lower half of the screen at all times.

To turn Automatic off, first press the AUTO key. A menu appears at the bottom of the screen above the left and right arrows. Press the left arrow key to switch to the manual mode. The letters "Man" appear in the upper left corner of the display, indicating the unit

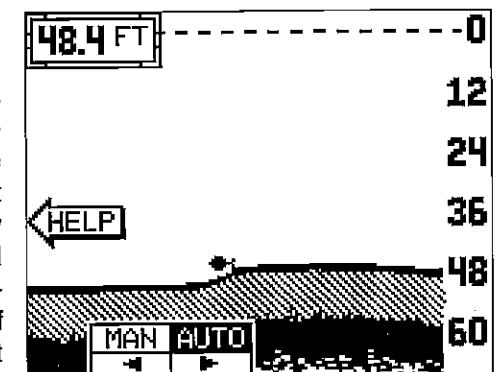

is in the manual mode. To turn Automatic on, press the AUTO key again, then press the right arrow key.

SENSITIVITY

The sensitivity key on the X-55 controls the ability of the unit to pick up echoes. A low sensitivity level excludes much of the bottom information, fish signals, and other target information. High sensitivity levels enables you to see this detail, but it can also clutter the screen with many undesired signals. Typically, the best sensitivity level shows a good solid bottom signal with Grayline and some surface clutter.

When the X-55 is in the Automatic mode, the sensitivity is automatically adjusted to keep a solid bottom signal displayed, plus a little more. This gives it the capability to show fish and other detail.

However, situations occur where it becomes necessary to increase or decrease the sensitivity. This typically happens when you wish to see more detail, so an increase in sensitivity is indicated. The procedure to adjust it is the same whether the unit is in the automatic or manual mode.

To adjust the sensitivity, press the SENS key. The sensitivity adjust menu appears at the bottom of the screen.

The sensitivity menu has left and right arrows, plus a horizontal bar graph. The graph gives a visual indication of the sensitivity level. The number above the INC arrow also shows the percentage of sensitivity in use.

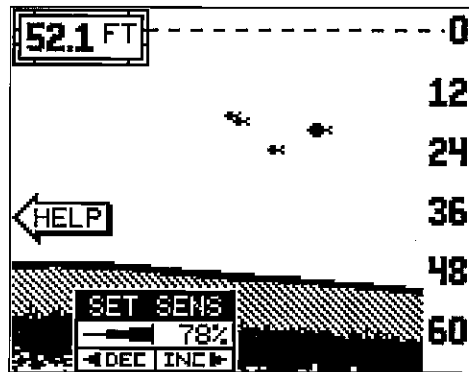

To increase the sensitivity level, press the right arrow key. As you press the key, the menu's bar graph will grow wider and the percentage will increase in value. You can also see the difference on the chart record as it scrolls. When the sensitivity is at the desired level, release the key.

To decrease the sensitivity level, press the key adjacent to the left arrow. The bar graph and percentage will decrease. When the sensitivity is at the desired level, release the key.

When you reach either the maximum or minimum limit, a tone sounds.

However, there are times when you may want to turn the ASP feature off. This allows you to view all incoming echoes before they are processed by the ASP feature.

To change the ASP level, press the MENU key five times. Then press the key next to the "ADJUST LEVEL OF CHART ASP" label until the desired level is obtained.

SIGNAL INTERPRETATION

Your X-55 gives an accurate picture of the bottom that your boat is passing. A bottom of firm sand, gravel, shell, or hard clay returns a fairly wide signal. If the automatic mode is off and the signal narrows down, then it means that you have moved over a mud bottom. Mud absorbs the sound wave and returns a weak signal. Turn up the sensitivity to see a better bottom signal.

Big rocks or stumps on a smooth bottom send back signals above the bottom level signal. The height of the signal depends on the target's height. As you pass over a post, it should be clearly visible as a short line extending above the bottom signal.

A steep slope returns a wide signal, the steeper the wider. Signals returned from a high underwater cliff are usually the widest of all.

When the Fish I.D. mode is off, the depth of the water will affect the size and shape of the fish arch due to the cone angle diameter. For example, if the cone passes over a fish in shallow water, the signal displayed on the X-55 may not arch at all. This is due to the narrow cone diameter and the resolution limitations of the display.

MENU - PAGE 5

ADJUST CHART SURFACE CLARITY

The markings extending downward from the zero line on the chart are called "surface clutter." These markings are caused by wave action, boat wakes, temperature inversion, and other natural causes.

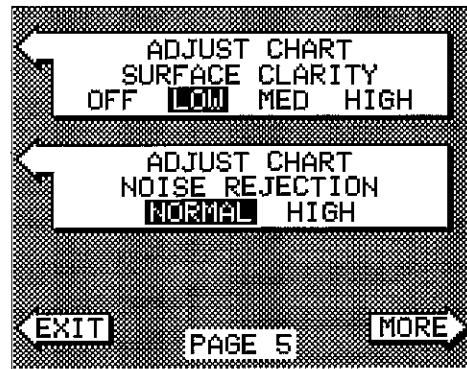

The Surface Clarity Control (SCC) reduces or eliminates surface clutter signals from the display. SCC varies the sensitivity of the receiver, decreasing it near the surface and gradually increasing it as the depth increases. The maximum depth that SCC will affect is 75% of the selected depth range. For example, on a 0-60 foot range with maximum SCC, surface clutter will be reduced down to 45 feet.

There are three levels of SCC available on the X-55: low, medium, and high. When it's turned on for the first time, the SCC level is low. To change it, press the MENU key five times, then press the key adjacent to the "ADJUST CHART SURFACE CLARITY" label until the black box is on the desired SCC level.

Press the key next to the "EXIT" label when you're finished.

ASP (Advanced Signal Processing)

The ASP feature is a noise rejection system built into the X-55 that constantly evaluates the effects of boat speed, water conditions, and interference. This automatic feature gives you the best display possible under most conditions.

The ASP feature is an effective tool in combating noise. In sonar terms, noise is any undesired signal. It is caused by electrical and mechanical sources such as bilge pumps, engine ignition systems and wiring, air bubbles passing over the face of the transducer, even vibration from the engine. In all cases, noise can produce unwanted marks on the display.

The ASP feature has two levels - Normal and High. If you have high noise levels, try using the "High" ASP setting. However, if you are having trouble with noise, we suggest that you take steps to find the interference source and fix it, rather than continually using the unit with the high ASP setting.

To turn the menus off, press the key adjacent to the CLEAR key at the bottom left side of the unit or wait a few seconds and the menu will disappear.

RANGE - Automatic

When turned on for the first time, the X-55 automatically places the bottom signal in the lower half of the screen. This is called Auto Ranging and is part of the automatic function. The range cannot be changed manually while the unit is in automatic.

RANGE - Manual

The X-55 gives you control over the range when it's in the manual mode.

To change the range, first make certain the X-55 is in the manual mode. Next, press the RANGE key. The range adjustment menu appears in the lower right corner of the display. Press the up or down arrow keys to decrease or increase the range. The available ranges are 0-5, 10, 20, 30, 40, 60, 100, 150, 200, 300, 500, 800, and 1000 feet. After the desired range is displayed, press the CLEAR key to erase the range menu.

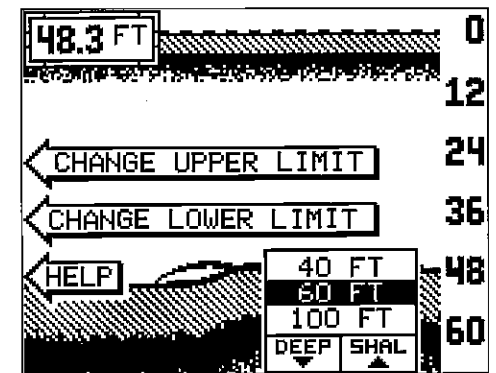

NOTE: The depth capability of the X-55 depends on the transducer installation, water and bottom conditions, and other factors.

RANGE - Upper and Lower Limits

The X-55 lets you change the upper and lower range limits when it's in the manual mode. This lets you "zoom" in on segments of the water as small as 5 feet. In other words, you can set the upper limit to 30 feet and the lower limit to 35 feet, regardless of the bottom depth. This in essence, gives you a 5 foot zoom. You can choose any segment of the water, as long as the distance between the upper limit and lower limit is 5 feet (2 meters, 1 fathom) or more. Using the zoom feature (described in the next section) lets you view a segment of the water on the screen's right side (for example, from 20 to 30 feet), and a zoom of that segment on the left.

To change the upper or lower limit, first make certain the unit is in the manual mode.

Next, press the RANGE key. The menu shown on the previous page appears. Now press the key next to the "CHANGE UPPER LIMIT" label to change the upper limit or "CHANGE LOWER LIMIT" label to change the lower limit. We're changing the upper limit in this example. After pressing the key next to the "CHANGE UPPER LIMIT" label, the screen shown at right appears.



Using the numbered keys, enter a number for the upper limit that is at least five feet less than the lower limit. In this case, we entered 40, giving a 20 foot zoom. When you've entered the desired upper limit, press the up arrow key at the bottom of the screen. The unit returns to the sonar screen with the new upper limit.

Change the lower limit the same way. Using the upper and lower limits in this manner lets you expand a segment of water quickly and easily.

ZOOM

Enlarging or "zooming" the picture is a common method used to show small detail and fish signals. The X-55 gives you two different zoom sizes, plus a split screen zoom option. The zoom operation and adjustment is different in the automatic and manual modes.

ZOOM - AUTOMATIC MODE

To zoom the display in the automatic mode, first press the ZOOM key. All targets on the display are enlarged four times normal size automatically. The menus shown at right also appear.

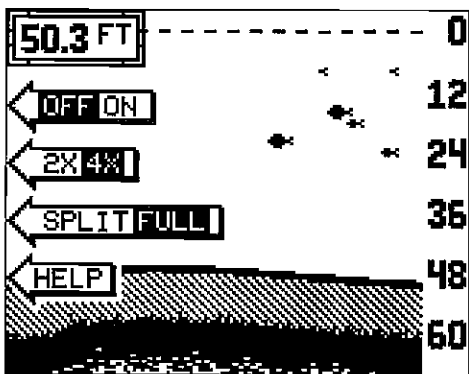

Turn the zoom feature on (or off) by pressing the key adjacent to the "OFF/ON" label.

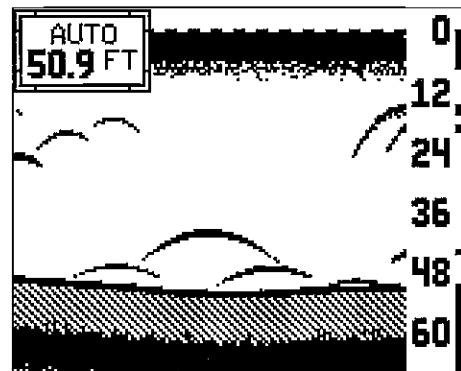

chor. Since the unit is not moving, fish signals are long, drawn out lines on a normal chart display. FASTRAK converts the graph to a vertical bar graph that, with practice, makes a useful addition to fishing at a stationary location.

To turn FASTRAK on, press the menu key four times, then press the key adjacent to the "TURN FASTRAK ON" label.

To turn it off, repeat the same steps. The "TURN FASTRAK OFF" label appears instead of the "TURN FASTRAK ON" label.

SELECT UNITS OF MEASURE

The X-55 can display the water depth in feet, fathoms, or meters, surface water temperature in degrees Fahrenheit or Celsius, speed in statute miles per hour, kilometers per hour, or knots, and distance (log) in miles, kilometers, or nautical miles.

To change the units of measure, press the key adjacent to the "SELECT UNITS OF MEASURE" label. The screen shown below appears. The black box on each line shows the unit of measure currently in use. In the screen shown below, the units of measure are in feet for the depth, temperature in degrees Fahrenheit, and both speed and log are in statute miles per hour.

Press the key adjacent to the unit that you wish to change. For example, press the key next to the DEPTH label two times to switch from feet to meters. This moves the black box two times from the "FT" to the "M". When you have the units of measure set as desired, press the key next to the "EXIT" label.

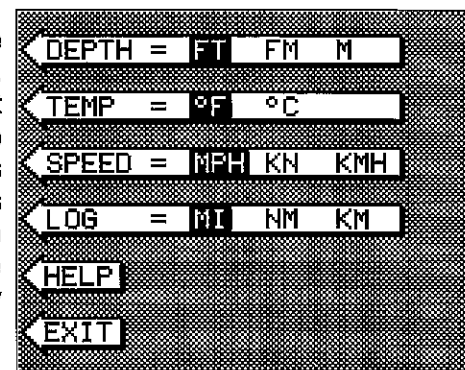

CLEAR DISTANCE LOG

The X-55 starts counting distance as soon as the X-55 is turned on. To reset the distance log to zero, press the MENU key until the "CLEAR DISTANCE LOG" label appears, then press the key adjacent to that label.

menu page appears, then press the key adjacent to the "REMOVE ZOOM BAR" label.

Note: Turning the zoom bar on also turns the zoom feature on.

DISPLAY ZONE BAR

When the zone alarm is on, the zone bar doesn't normally show on the screen. To turn the zone bar on continuously, first press the MENU key until the 3rd menu page appears. Now press the key next to the "DISPLAY ZONE BAR" label.

To turn the zone bar off, press the MENU key until the third menu page appears, then press the key adjacent to the "REMOVE ZONE BAR" label.

Note: Turning the zone bar on also turns the zone alarm on.

DIGITAL SONAR

When the X-55 is turned on for the first time, the digital depth display is located at the top left corner of the screen. This display comes from a separate digital sonar built into the unit. It displays only the bottom depth. If it loses the bottom, the last known depth will flash on the display. When the digital finds the bottom, it will automatically display the bottom depth again.

The digital sonar can be turned off, however this also turns all automatic features off also, such as auto sensitivity, auto ranging, and the Fish I.D. feature.

To turn the digital sonar off, press the Menu key three times. Now press the key adjacent to the "TURN DIGITAL SONAR OFF" label. To turn it back on again, repeat the same steps.

MENU - PAGE 4

FASTRAK

This feature converts all echoes to short horizontal lines on the display's far right side. The graph continues to operate normally. FASTRAK gives you a rapid update of conditions directly under the boat. This makes it useful for ice fishing, or when you're fishing at an

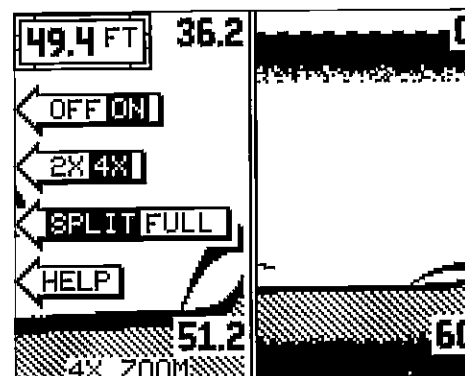
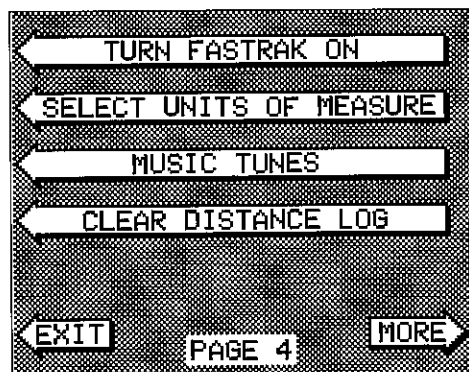

Pressing the key adjacent to the "2X/4X" label enlarges echoes from two times to four times their normal size.

To switch between the split screen zoom and full screen zoom, press the key adjacent to the "SPLIT/FULL" label. The screen instantly splits into two sections as shown at left. All

targets on the left are shown at four times the size of the ones on the right. If you switch to the 2X zoom mode, echoes on the left side of the screen are shown at twice the size as the ones on the right. The echoes that scroll across the screen are the exact same echoes on both sides of the screen. They're simply enlarged on the left side. This feature tracks the bottom, keeping it on the display at all times, when the automatic feature is on. Once you've set the zoom as desired, press the CLEAR key to erase the menus.

ZOOM - MANUAL MODE

When you press the zoom key while the unit is in the manual mode, the screen shown below appears. All of the menus on this screen work identically as described above. However, one additional menu item is shown when the unit is in the manual mode: "ADJUST".

To adjust the zoom, press the key adjacent to the "ADJUST" label. A screen similar to the one below appears. A zoom bar and adjust arrows appear on the screen. The echoes on the left side of the screen are the ones that appear between the top and the bottom of the zoom bar. Press the up or down arrow keys to move the zoom bar up or down. As you adjust the zoom bar, the echoes move on the left side of the screen at the same time. The zoom adjust menu will automatically clear a few seconds after you've pressed the last key. Remember, the X-55 won't track the bottom when it's in the manual mode.

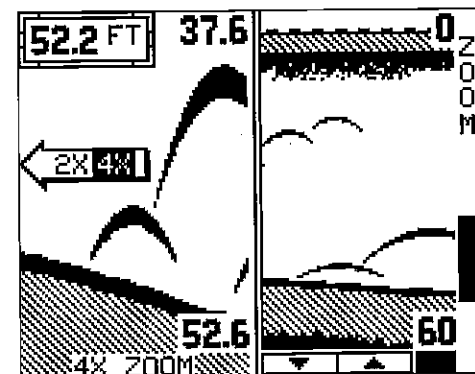

SONAR ALARMS

The X-55 has three different types of sonar alarms. The first is the Fish Alarm. It sounds when the Fish I.D. feature determines an echo or group of echoes is a fish. Another alarm is the Zone Alarm which consists of a bar. Any echo that appears inside this bar triggers the alarm. The last alarm is called the Depth Alarm. Only the bottom signal will trigger this alarm. This is useful as an anchor watch, a shallow water alert, or for navigation. See the GPS section for information on GPS alarms.

To adjust an alarm, first press the ALARM key. The screen shown below appears. Press the key next to the "SET DEPTH OR GPS ALARMS" to adjust the shallow or deep digital alarms. When you press the key next to the "SET DEPTH OR GPS ALARMS", the menu shown at the top of the next page appears. The zone

alarm has its own menu which is shown and described in the zone alarm section. Once you see this screen, press the down arrow key until the black box is on the desired alarm. In this example, the shallow alarm is selected. Now press the key next to the "CHANGE VALUE" label. Use the numbered keys to set the alarm. For example, to set the shallow alarm's value to 10 feet, press the 1 key, then press the 0 key. When the desired value has been entered, press the key next to the "ENTER" label. The unit returns to the ALARMS screen.

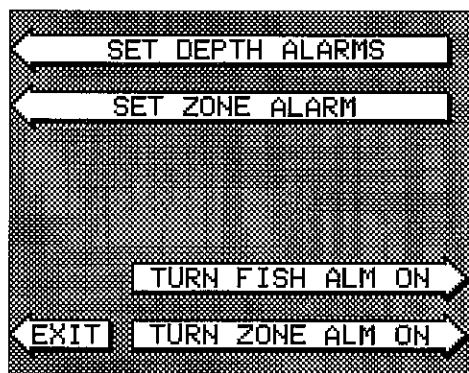

When either depth alarm sounds, a "Silence Alarm" label appears at the bottom of the screen. Press the "CLEAR" key to mute the alarm. When the alarm is triggered again, the alarm will also sound.

The following section describes each sonar alarm and its limits.

FISH ALARM

Use the fish alarm for a distinctive audible alarm when fish or other suspended objects are detected by the Fish I.D. feature. A different tone sounds for each fish symbol size shown on the display.

MENU - PAGE 3

CHART CURSOR

The X-55 has a chart cursor that allows you to pinpoint a target's depth. The cursor is simply a horizontal line that extends across the display from left to right. A depth box at the end of the line on the right side shows the line's depth. In the example below, the cursor (line) is at 30.0 feet.

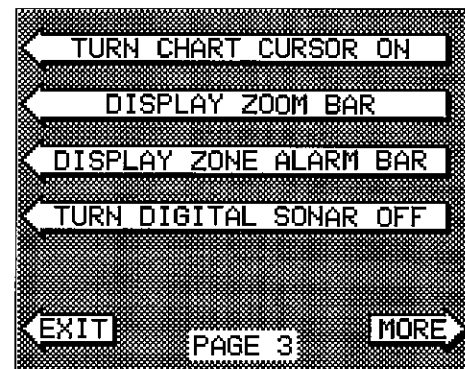

To display the chart cursor, press the menu key three times. Now press the key adjacent to the "TURN CHART CURSOR ON" label. A screen similar to the one at the bottom of this page appears. Use the up or down arrow keys to move the cursor up or down to the desired depth.

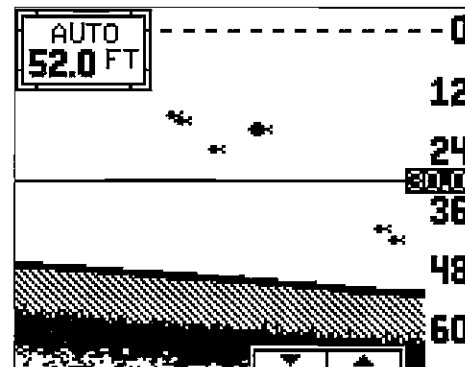

To turn the chart cursor off, press the menu key three times. Now press the key adjacent to the "TURN CHART CURSOR OFF" label. The X-55 returns to the sonar screen without the chart cursor.

DISPLAY ZOOM BAR

When the unit is in the zoom mode, the zoom bar doesn't normally show on the screen. The zoom bar shows the section of water on the right side of the screen that the zoom feature displays on the left side. To turn the zoom bar on continuously, first press the MENU key until the 3rd menu page appears. Now press the key next to the "DISPLAY ZOOM BAR" label.

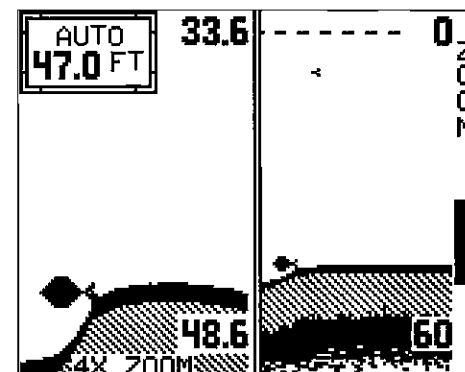

To turn the zoom bar off, press the MENU key until the third

TURN DIGITAL BOX OFF

The digital box is displayed in the upper left corner of the full sonar screen. It has the digital depth and automatic/manual indicators. To turn this box off, press the MENU key twice, then press the key adjacent to the "TURN DIGITAL BOX OFF" label. Repeat the above steps to turn the box on.

CONSTRUCT DIGITAL BOX

The X-55 can display the depth, speed, surface water temperature, and distance log in the upper left portion of the screen. When the X-55 is first turned on, only the depth is displayed. You can turn each digital display on as desired or turn all of them off, as desired.

To select the digital displays menu, first press the menu key three times. Next, press the key adjacent to the "CONSTRUCT DIGITAL BOX" menu. A screen appears that is similar to the one below.

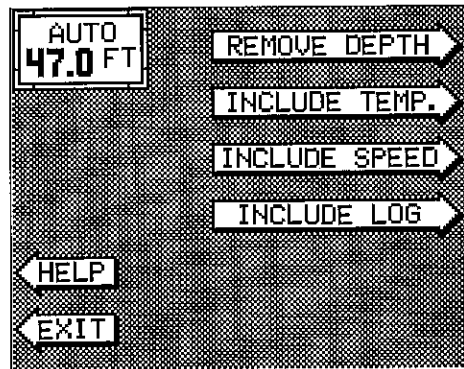

Now press the key adjacent to the desired display. For example, to turn the temperature display on, press the key adjacent to the "INCLUDE TEMP." label. Once you do this, the digital display in the corner of the screen will show the temperature in addition to the depth. The temperature menu label now shows "REMOVE TEMP." You can turn each display on or off individually.

Press the CLEAR key to exit from this menu or wait approximately ten seconds and the menus will automatically clear.

To turn the entire digital box off, press the MENU key twice, then press the key next to the "TURN DIGITAL BOX OFF" label. The unit will return to the sonar display with the digital box erased from the screen. To turn it on again, repeat the above steps. The label on the second menu page now reads "TURN DIGITAL BOX ON."

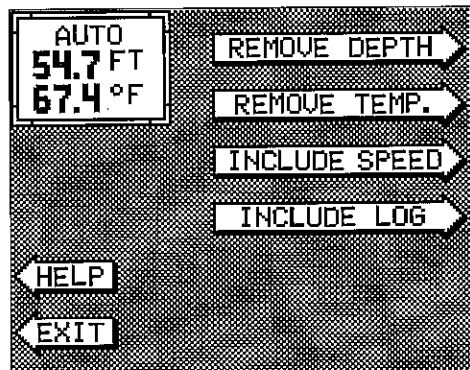

ZONE ALARM

The zone alarm consists of a bar that appears on the right side of the screen. Any echo that appears on the screen between the top and bottom of the zone alarm's bar will "trip" the zone alarm.

Note: The zone alarm isn't available in the Windows mode.

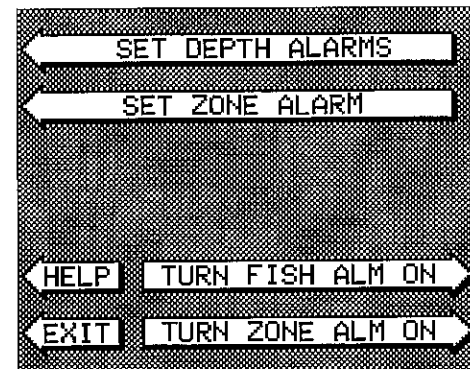

To set the zone alarm, press the ALARM key. Now press the key next to the "Set Zone Alarm" label. A screen similar to the one shown below appears.

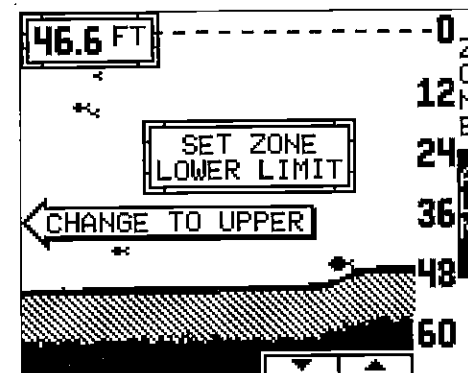

The zone alarm bar shows on the right side of the screen. Use the arrow keys to move the bottom of the bar higher or lower. To move the top of the bar, first press the key next to the "CHANGE TO UPPER" label. Now use the arrow keys to move the top of the bar higher or lower. When you have the zone alarm bar set as desired, press the CLR key to erase the menus.

The above steps automatically turn the zone alarm on if it was off. To turn the zone alarm off, press the ALARM key, then press the key next to the "Turn Zone Alarm Off" label at the bottom of the screen.

Normally, the zone alarm bar disappears from the screen after you make adjustments. To leave the zone alarm bar on the screen all of the time, see the "Display Zone Alarm Bar" section in this manual for instructions.

DEPTH ALARMS

The depth alarms sound a tone when the bottom signal goes shallower than the shallow alarm's setting or deeper than the deep alarm's setting. For example, if you set the shallow alarm to ten feet, the alarm will sound a tone if the bottom signal is less than ten feet. It will continue to sound until you mute it or until the bottom goes deeper than 10 feet. The deep

alarm works just the opposite. It sounds a warning tone if the bottom depth goes deeper than the alarm's setting. Both depth alarms work only off the digital bottom depth signals. No other targets will trip these alarms. These alarms can be used at the same time or by themselves.

To set the depth alarms, first press the ALARM key, then press the key next to the "SET DEPTH ALARMS" label. The screen at the top of this page appears.

To adjust the shallow alarm, press the key next to the "Shallow" label. To adjust the deep alarm, press the key next to the "Deep" label. Both alarms adjust identically. We'll use the shallow alarm as an example. Pressing the key next to the "Shallow" label moves the black box from the "OFF" position to the number on the right side of the arrow. A new label appears at the bottom of the screen: "CHANGE LIMIT." Press the

key next to that label. A new screen appears as shown at the top of the next page. Use the numbered keypad on the right side of the unit to enter the shallow alarm setting. We used 10 feet in this example.

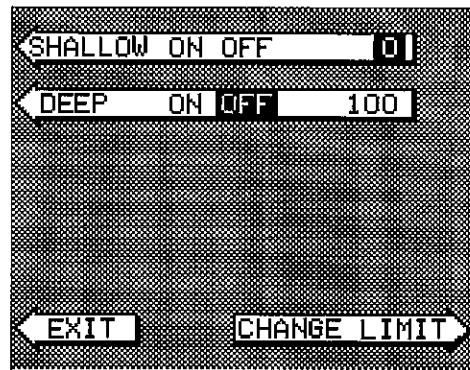
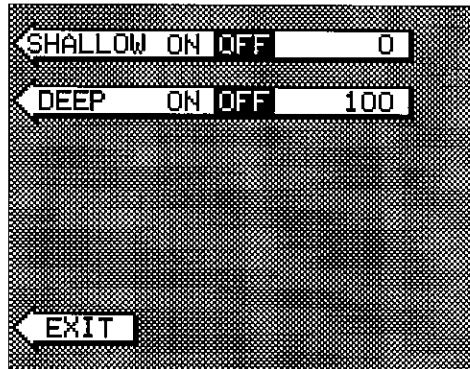

MENU - PAGE 2

ADJUST BACK LIGHT LEVEL

The X-55 has internal lights for the display and keyboard. To adjust the intensity of the lighting, press the MENU key twice, then press the key adjacent to the "ADJUST BACK LIGHT LEVEL" label. The screen shown below appears. Now press the left arrow key to decrease the light level. Press the right arrow key to increase it. The percentage of back light in use changes as the arrow keys are pressed. The bar chart also gives a graphical indication of the level. After you've made the adjustment, press the CLEAR key to erase the menu.

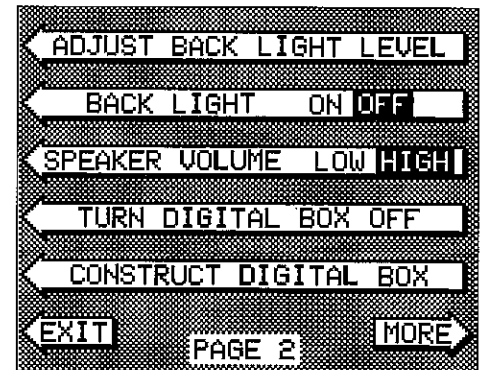

BACK LIGHT ON/OFF

To turn the back lighting on, press the menu key twice, then press the key adjacent to the "BACK LIGHT" label. This moves the black box from "OFF" to the "ON" position. To turn the backlights off, repeat the same steps.

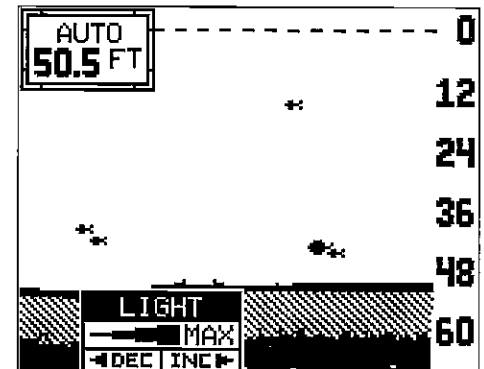

SPEAKER VOLUME

The speaker volume has two levels: high or low. When the X-55 is first turned on, the speaker volume is high. To change it, press the MENU key twice, then press the key next to the "SPEAKER VOLUME LOW HIGH" key. This switches the volume from high to low. A short tune sounds, letting you hear the volume. To switch back to high, simply press the key again.

To exit from this menu, press the CLEAR key.

outwards from a group of limbs is the hardest object for the Fish I.D. feature to distinguish from fish. You may see Fish I.D. symbols on the screen when actually, there are no fish. Practice with the unit in both the Fish I.D. mode and without to become more familiar with the Fish I.D. feature.

To turn the Fish I.D. feature on, press the menu key, then press the key adjacent to the "Turn Fish-ID On" label. Echoes will continue to scroll across the screen, however, the surface clutter at the top will no longer be displayed. Any targets the micro-computer determines are fish will be displayed as fish symbols. To turn the Fish I.D. feature off again, first press the menu key. Next, press the key adjacent to the "Turn Fish I.D. Off" label. The menu immediately disappears and the sonar screen returns.

Remember, the Fish I.D. feature can't be used when the X-55 is in the manual mode. If you turn the Fish I.D. feature on when the X-55 is in manual, the micro-computer will turn the automatic feature on. If you turn automatic off when the Fish I.D. feature is on, the Fish I.D. feature will be turned off also.

DISPLAY CONTRAST

The unit's display contrast is adjustable to suit different lighting conditions. To adjust it, first press the menu key. The first menu page appears. Now press the key next to the "ADJUST DISPLAY CONTRAST" label. A screen similar to the one below appears. Now press the key adjacent to the left arrow to decrease the contrast. Press the key adjacent to the right arrow to increase it. The percentage of contrast in use changes as the arrow keys are pressed. The bar chart also gives a graphical indication of the contrast level. You can see the change on the screen as you press the keys. After you've made the adjustment, press the CLEAR key to erase the menu.

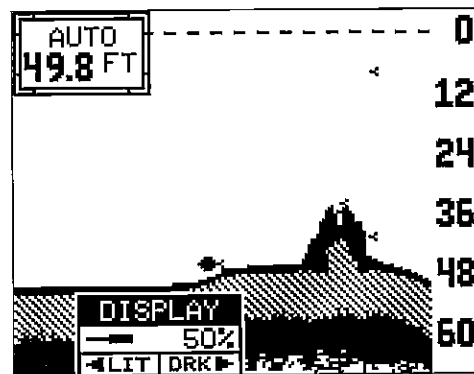

After you've entered the desired alarm depth, press the key next to the "ACCEPT" label. This enters the alarm depth into memory and automatically turns the shallow alarm on. Now press the key next to the "ACCEPT" label.

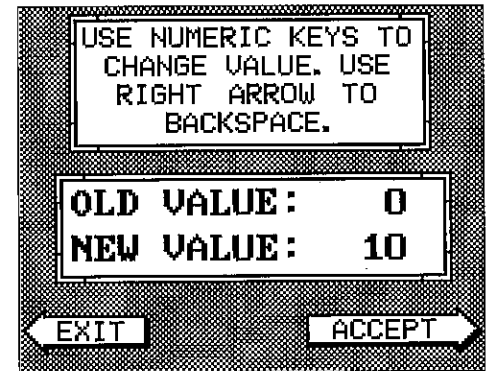

The screen shown at right appears next. The shallow alarm is now set. If the bottom goes shallower than 10 feet, the alarm will sound and a warning message appears on the screen at the same time. A label also appears letting you mute the alarm, if desired.

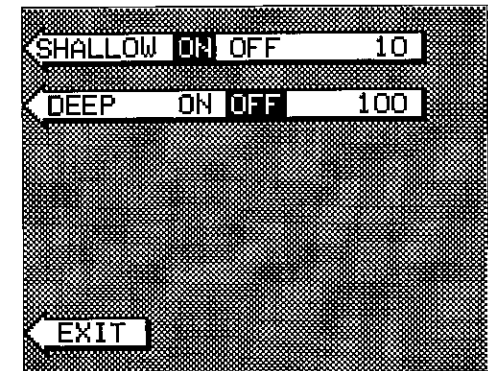

To return to the sonar screen, press the key next to the "EXIT" label.

ALARM MUTE

When either the shallow or deep alarm is triggered, an audio tone sounds. A different tone sounds for the shallow than the deep alarm, thus letting you know which alarm is sounding without looking at the unit. Once a depth alarm is triggered, it keeps sounding until you change depth. For example, if the shallow alarm is set to 10 feet, and you move into and stay in water that's five feet deep, you're going to get tired of listening to the alarm beeping all the time.

To keep this situation from happening, a new label appears on the sonar screen whenever a depth alarm sounds. This label says "Silence Alarm". This turns the alarm's sound off until it's triggered again.

MENU - PAGE 1

CHART SPEED

The rate echoes scroll across the screen is called the chart speed. It's adjustable by first pressing the menu key, then pressing the key adjacent to the "ADJUST CHART SPEED" label. The chart speed menu appears at the bottom of the screen. Increase the chart speed by pressing the right arrow key or decrease it by pressing the left arrow key. The percentage of chart speed in use changes as the arrow keys are pressed. The bar chart also gives a graphical indication of the chart speed. You can see the change on the screen (both on the menu and on the chart record) as you press the keys. After you've made the adjustment, press the CLEAR key to erase the menu.

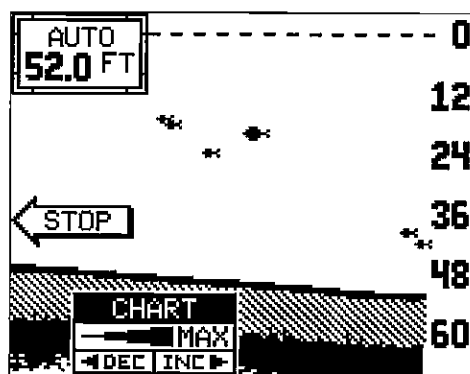
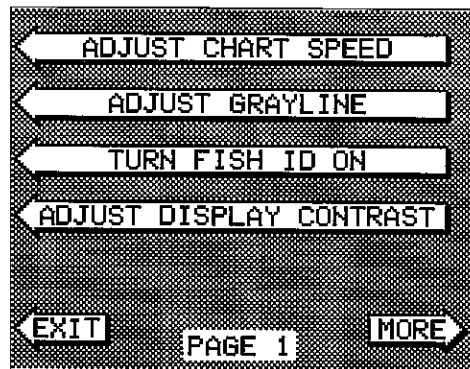

To stop the chart, press the "STOP" key in the unit's lower left corner. To start the chart, press the "STOP" key again.

GRAYLINE®

GRAYLINE lets you distinguish between strong and weak echoes. It "paints" gray on targets that are stronger than a preset value. This allows you to tell the difference between a hard and soft bottom. For example, a soft, muddy or weedy bottom returns a weaker signal which is shown with a narrow or no gray line. A hard bottom returns a strong signal which causes a wide gray line.

If you have two signals of equal size, one with gray and the other without, then the target with gray is the stronger signal. This helps distinguish weeds from trees on the bottom, or fish from structure.

GRAYLINE is adjustable. Since GRAYLINE shows the difference between strong and weak signals, adjusting the sensitivity may require a

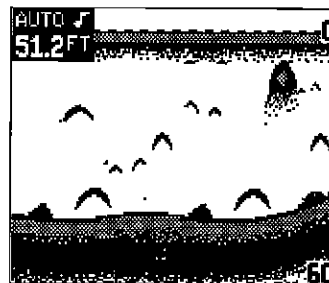

GRAYLINE® ON

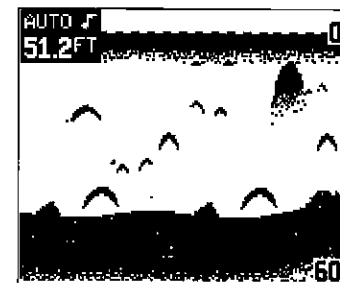

GRAYLINE® OFF

different GRAYLINE level, also. The level chosen by the X-55 at power on is usually adequate for most conditions. Experiment with your unit to find the GRAYLINE setting that's best for you.

To adjust GRAYLINE, press the MENU key, then press the key adjacent to the "ADJUST GRAYLINE" label. A screen similar to the one at right appears. Now press the left arrow key to decrease the gray level. Press the right arrow key to increase it. The percentage of GRAYLINE in use changes as

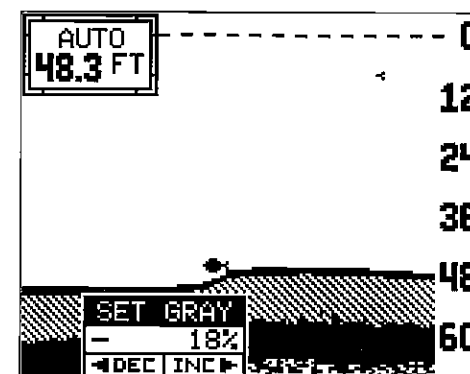

the arrow keys are pressed. The bar chart also gives a graphical indication of the GRAYLINE level. You can see the change on the screen (both on the menu and on the chart record) as you press the keys. After you've made the adjustment, press the CLEAR key to erase the menu.

FISH I.D.

The Fish I.D. feature identifies targets that meet certain conditions as fish. The micro-computer analyses all echoes and eliminates surface clutter, thermoclines, and other signals that are undesirable. In most instances, remaining targets are fish. The Fish I.D. feature displays symbols on the screen in place of the actual fish echoes. There are four fish symbol sizes: tiny, small, medium, and large. These are used to designate the relative size between targets. In other words, it displays a small fish symbol when it thinks a target is a small fish, a medium fish symbol on a larger target, etc.

The micro-computer is sophisticated, but it can be fooled. It cannot distinguish between fish and other suspended objects such as trotlines, turtles, submerged floats, air bubbles, etc. Individual tree limbs extending